

# GEO FLOORING

A 3D architectural rendering of a modern staircase. The stairs feature grey, ribbed treads and a red handrail. A person is visible on the left side of the stairs, and another person is on the right side. The text 'GEO FLOORING' is overlaid in large, white, sans-serif font across the top of the image.

**AB Pure Stair Treads**

# AB Pure Stair Treads

---

Today stair treads are more than just a material to avoid slippage, they have become an integral part of the overall design statement. Recognising this need, American Biltrite introduces a complete stair tread system that delivers on the promise of colour and design, safety and durability, as well as ease of maintenance.



**AB Pure® rubber flooring products are Red List Free and part of the Living Building Challenge Declare Program.**

## What is Declare?

The program provides a clear and informative label for building products and supports the Living Building Challenge's Red List for material transparency and toxic chemical avoidance as well as simplifying material specification and project certification.

What is the Red List and what does it mean to be Red List Free?

The Red List represents the "worst in class" materials, chemicals, and elements known to pose serious risks to human health and the greater ecosystem. For a product to be awarded Red List Free status means that it does not contain any ingredients on the Living Building Challenge Red List.

To learn more about the Living Building Challenge, visit [www.living-future.org/lbc](http://www.living-future.org/lbc).

**Declare.** 

# AB Pure Stair Treads

Offering a comprehensive selection of stair treads in both regular stair treads and stair treads with riser combinations.

Available in two designs; Round and Hammered.

The system is complemented with the addition of a landing tile that matches the stairtread in Round and Hammered designs.

The entire program is Declare "Red List Free".

## Stair Tread System

Featuring tread, nose and riser in a single piece  
**AS 1428.1-2009 Compliant**

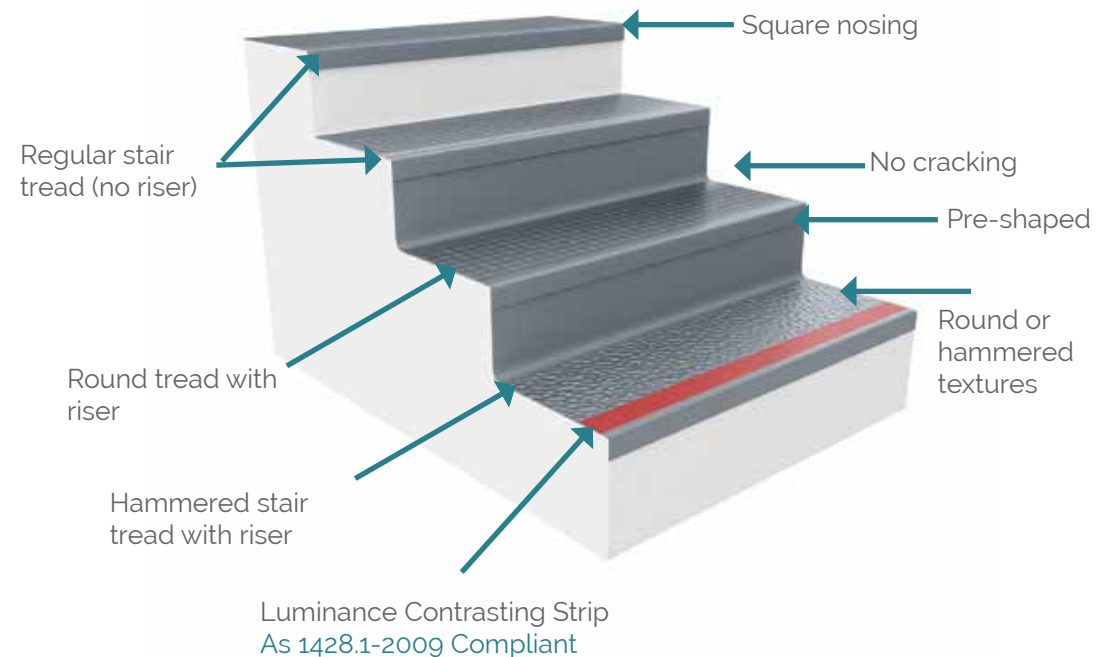

# AB Pure Stair Treads

---



## Luminance Contrasting Strips AS 1428.1-2009 Compliant

These strips can be added to your stair treads for added traction and as a visual aid, and compliance with AS 1428.1-2009.



VIT-82 Nightglow



VIT-72 Yellow



VIT-22 Black



VIT-52 Red



VIT-15 White

# Stair Treads

---

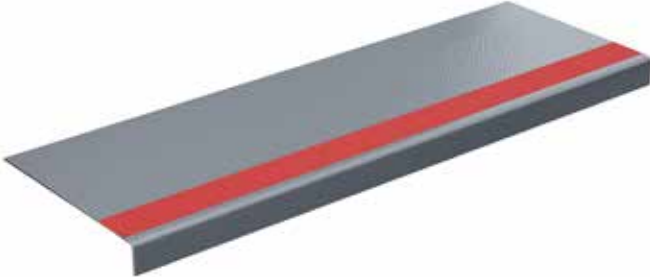

Regular Stair Treads - Hammered



Stair Treads with rise - Hammered

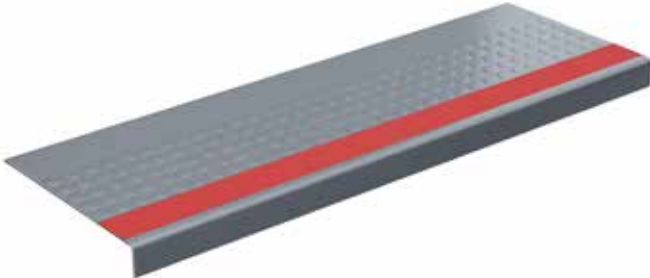

Regular Stair Treads - Round

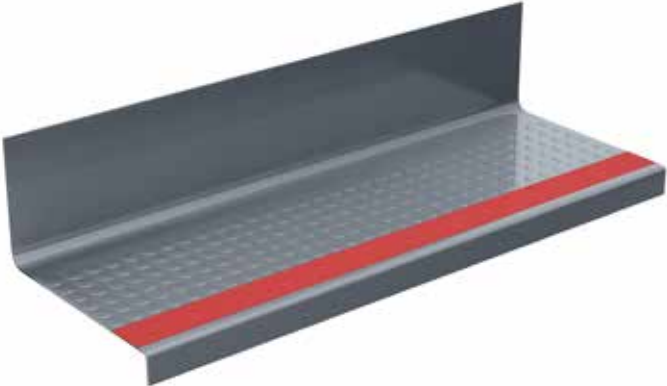

Stair Treads with rise - Round

# Round Stair Treads



RTP-15 Snowstorm



RTP-35 Ash Gray

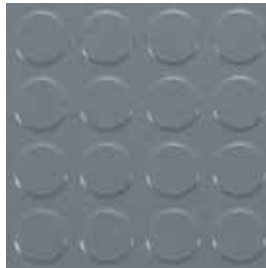

RTP-38 Steel

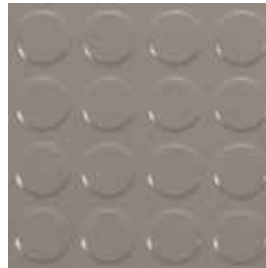

RTP-32 Appalachian Trail

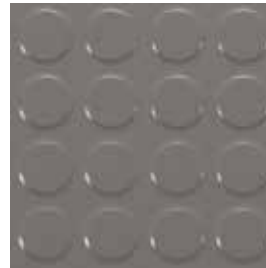

RTP-37 Battleship Gray

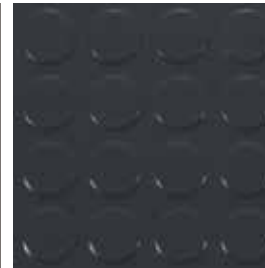

RTP-23 Anthracite

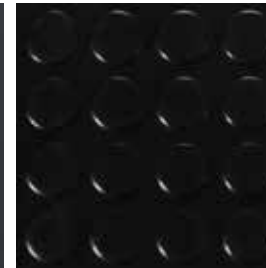

RTP-20 Starry Night



RTP-30 Sand Castle



RTP-45 Wheat



RTP-36 Tan

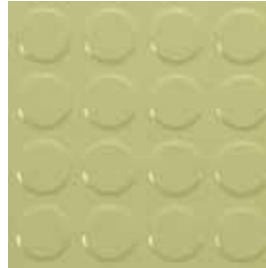

RTP-83 Pistachio

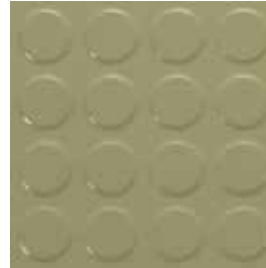

RTP-85 Olive Green

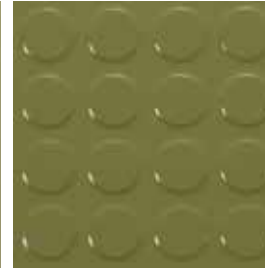

RTP-87 Tundra

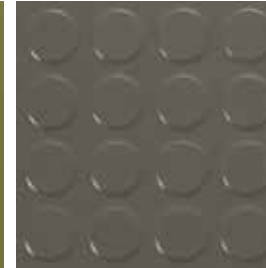

RTP-39 Camouflage Green



RTP-72 Limoncello



RTP-75 Orangerine

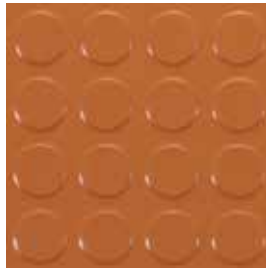

RTP-52 Terracotta

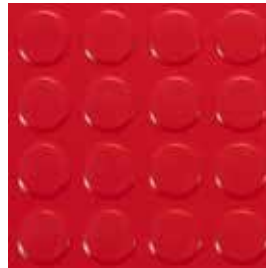

RTP-55 Fire Engine Red

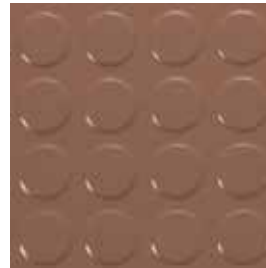

RTP-57 Chestnut

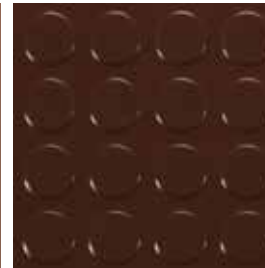

RTP-58 Espresso

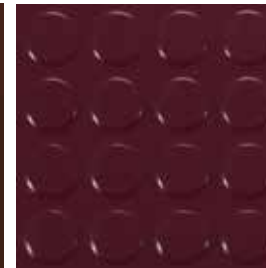

RTP-56 Shiraz



RTP-92 Aquamarine



RTP-98 Blue Lagoon



RTP-95 Electric Blue

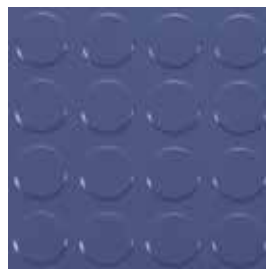

RTP-68 Rich Lavender



RTP-66 Doll House

# Hammered Stair Treads

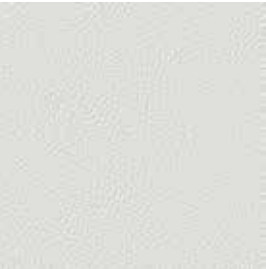

RTM-15 Snowstorm



RTM-35 Ash Gray

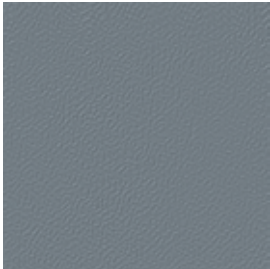

RTM-38 Steel



RTM-32 Appalachian Trail

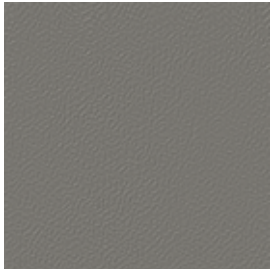

RTM-37 Battleship Gray

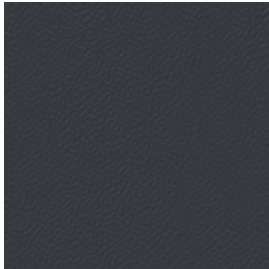

RTM-23 Anthracite



RTM-20 Starry Night



RTM-30 Sand Castle



RTM-45 Wheat



RTM-36 Tan



RTM-83 Pistachio



RTM-85 Olive Green



RTM-87 Tundra

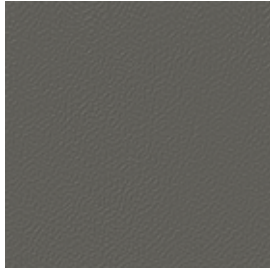

RTM-39 Camouflage Green



RTM-72 Limoncello



RTM-75 Orangerine



RTM-52 Terracotta



RTM-55 Fire Engine Red



RTM-57 Chestnut



RTM-58 Espresso



RTM-56 Shiraz



RTM-92 Aquamarine



RTM-98 Blue Lagoon



RTM-95 Electric Blue



RTM-68 Rich Lavender



RTM-66 Doll House

# Specifications

AS 1428.1-2009 Compliant

Gauge	Round: 3.17 mm, Hammered: 3.5 mm
Sizes	0.914 m 1.219 m 1.828 m
Depth	314mm Stair Tread without riser 482 mm Stair tread with riser
Nosing Depth	47 mm
Nosing Radius	6 mm
ASTM E 648 – Critical Radiant Flux CRF (W/cm <sup>2</sup> )	> 0.45 Australian Standards Compliant
ASTM E 662 – Smoke Density	≤ 450 Australian Standards Compliant
ASTM F 925 – Chemical Resistance	Meets requirements (details upon request)
ASTM F 1514 – Heat Stability	≤ 8
ASTM F 1515 – Light Stability	≤ 8
ASTM F 2169 – Resilient Stair Treads	Type TS Rubber Vulcanised Thermoset - Class 2 Group 1 & 2 (Luminance Safety Strip)
Indoor Air Quality (IAQ) Volatile Organic Compounds (VOC's)	Floorscore® Certified by SCS Certification Registration Number SCS-FS-01492a
Limited Wear Warranty	10 years
Resistance to oils and greases - ABPURE® is not recommended for environments where it could be exposed to oils and greases, whether mineral, animal or vegetable.	
Antimicrobial/Antifungal - IMPORTANT: All ABPURE® rubber flooring contains inhibitors that gives this flooring antimicrobial and antifungal properties.	